

RhinoStud™

RMS7000

the future of reflective road studs

RhinoStud™ is the first Reflective Road Stud to offer Africa's road designers and road builders the strength and durability of metal embodiment with the flexibility and cost effectiveness of injection moulding. With its superior strength, unique patented design, unsurpassed reflective performance and the flexibility to be custom manufactured to specific customer requirements at short notice RhinoStud is an African road stud custom designed and developed for Africa's harsh conditions.

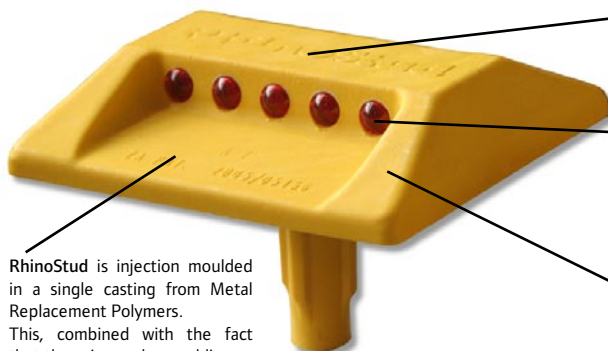

RhinoStud's low overall height of 21,2mm and rounded edges presents road users with a low impact road stud designed to minimize wear and tear to vehicle tyres and suspension systems.



RhinoStud utilizes the finest Swareflex crystal lenses in a 5 X 8mm lens configuration that delivers the finest and most durable reflective parameters in the world.

RhinoStud is injection moulded in a single casting from Metal Replacement Polymers. This, combined with the fact that there is no glue, welding or crimping in the manufacturing process, results in metal strength at up to 60% of the cost of conventional metal based studs. As the embodiment has no scrap value RhinoStud will not be lost to pilfering for scrap.

RhinoStud's unique patented ramps ensure that vehicle tyres never come into direct contact with the reflective lenses thereby ensuring their prolonged optical integrity beyond conventional road stud designs. The ramps are engineered at a very gentle 25° angle dramatically reducing energy transfer from vehicle tyres on impact. Conventional road studs present impact faces of 30° to 90°.

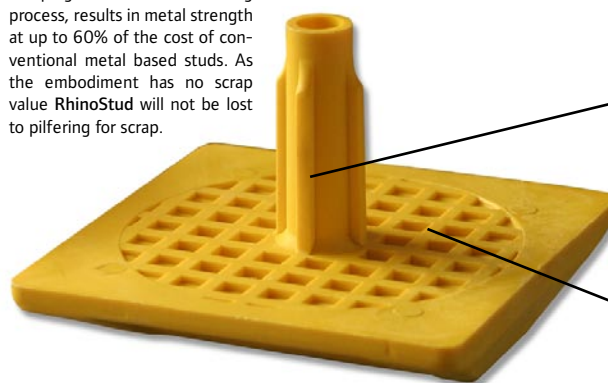

RhinoStud is available with and without a shank. The shank is hollow allowing for superior bonding during insertion and the 4 anti-rotation blades ensure that RhinoStud will never be knocked out of alignment. The base of the shank is designed to shear clean from the main body and remain below the road surface during a catastrophic impact for enhanced safety to road users.

RhinoStud features a honeycomb base structure that maximises surface area along with a 1,000mm² footprint to provide enhanced bonding to the road surface.

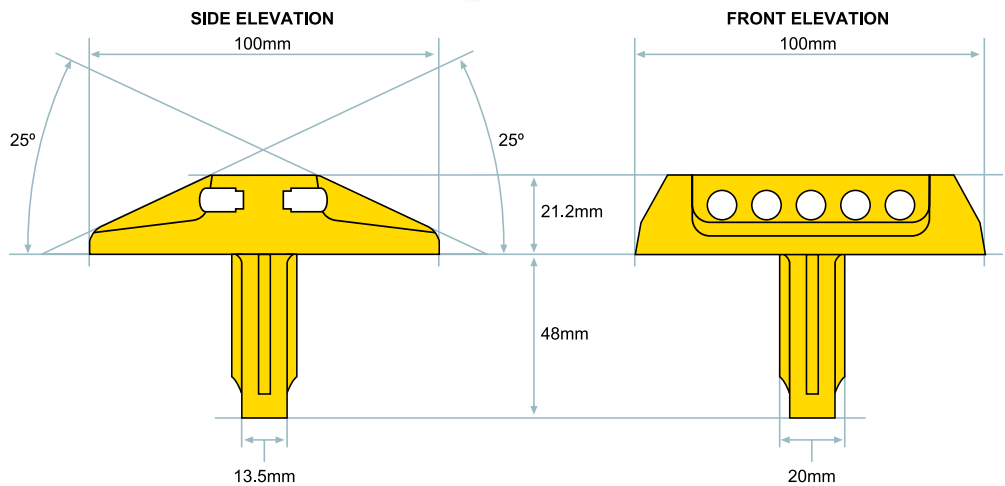

Embodiment:	Ultra-Flow glass reinforced Metal Replacement Polymer
Reflectivity:	Swareflex Glass crystal inserts 8mmx11mm 5 off either side
Dimensions:	100mm x 100mm x 21.8mm
Availability:	Manufactured in South Africa
Weight:	195 grams
Colours Embodiment:	White, Yellow, Red & Black
Colours Reflectors:	White, Yellow & Red
UV Resistance:	180 (kLy)
Tensile Strength at Break:	230 Mpa (33.3)
Tensile Modulus:	16,500 Mpa (2.390)
Tensile Strain at Break:	2.5%
Flexural Modulus:	14,000 Mpa (2.030)
Charpy Notched Impact Strength:	15 KJ/m2 (2.3)
Glass Crystals:	En 1463-1 Type P1A fulfilled

Standards:	EN 1463 BS 873/Part 4, CE
------------	---------------------------------

RhinoStud is manufactured in Durban, South Africa thereby ensuring rapid delivery to your project site. RhinoStud conforms to EU, SABS 1442 and SADC Road Standards offering the durability of metal fabricated road studs.

For more information about RhinoStud or if you would like a free sample or details about existing RhinoStud installations and test sites please contact:

Noel vd Westhuizen
GODUSA cc
P O Box 715
GILLITTS - KZN
3603



Phone: +27 (0)31-765-4731
Fax: +27 (0)31-765-5363
Cell No: +27 (0)82-323-6088
email: ncon@absamail.co.za

